

CENTRE SHUTTER LOCK - MODEL:S310/S320

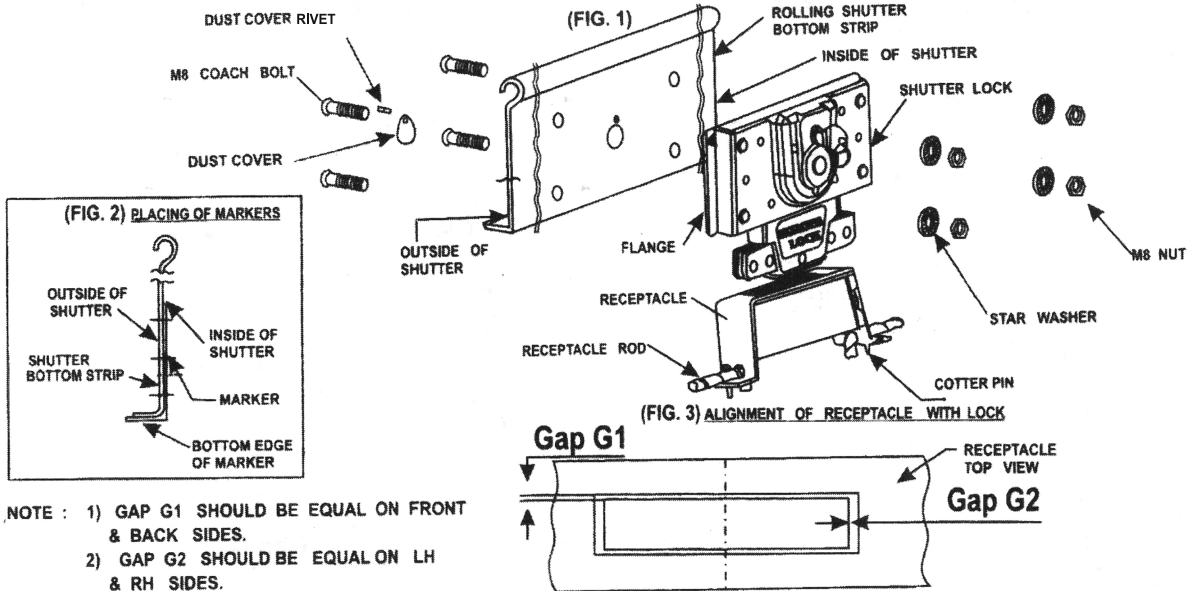

INSTALLATION PROCEDURE:

The EUROPA Center Shutter Lock is a high security locking system and it has to be installed correctly to ensure trouble free performance. Only an experienced technician should install it, strictly following the instructions mentioned below. Please contact your nearest Europa Lock dealer if you require any assistance.



NOTE : 1) GAP G1 SHOULD BE EQUAL ON FRONT & BACK SIDES.
2) GAP G2 SHOULD BE EQUAL ON LH & RH SIDES.

1. Fold the MARKER along the bottom edge (shown by dotted line). From inside of shutter place the MAEKER on the SHUTTER SECTION BOTTOM STRIP as shown in FIG.2
2. Mark centers 'A','B','C','D','P', and 'Q' (as shown on the MARKER) with center Punch. During marking ensure that the bottom edge MARKER should match to the bottom ben edge of SHUTTER bottom strip.
3. Drill 9mm.Dia. holes at centers 'A','B','C' and 'D' for mounting the lock.
4. Drill 18mm Dia. hole at center 'P' and 3mm Dia. at center 'Q'
5. To prevent the dust entering through the key hole, rivet the DUST COVER on the SHUTTER from outside at center 'Q' with RIVET supplied.
6. Fix the LOCK on the SHUTTER using M8 COACH BOLTS (provided with lock set). Two side FLANGES are provided for welding the LOCK with shutter. (IF POSSIBLE AVOID WELDING).

FIXING RECEPTACLE:

Use cement concrete mixture for fixing RECEPTACLE assembly. As shown in Fig.3 LOCK should enter the Receptacle in centered position so that there is equal gap on FRONT and BACK sides and on R.H. & L.H. sides. (Before pouring concrete mixture, keep engaged the two end locking levers of the Shutter.)

FINAL CHECKING OF LOCK OPERATION :

CONFIRM LOCK FUNCTION AS FOLLOWS

1. To LOCK the SHUTTER LOCK from OUTSIDE rotate the key by 150° anti clockwise. To OPEN it rotate the key by 150° clockwise. To remove the key, it should be on its original position in both cases.
2. To LOCK the SHUTTER LOCK from INSIDE, rotate the key by 360° and clockwise. To OPEN it rotate the key by 360° clockwise. Key can be removed after 360° rotation in either case (for S320 only.)
3. To confirm opening & closing of the LOCK possible, in wet condition of concrete.

WELMADE LOCKING SYSTEMS PRIVATE LIMITED.
J-61, MIDC, Bhosari, Pune - 411026. Maharashtra (India).
TEL : 2712 2546, 2712 2468
FAX : 91 (020) 2712 6204



WARRANTY CERTIFICATE

This product with the dimple key / 5 Pin Key is warranted to be free from mechanical defects for a period of 15 / 7 years respectively from the date of manufacture mentioned on the product. Damage due to abuse or neglect or wrong fitment, faulty installation is not covered. To get service under this warranty the product along with this warranty certificate & original purchase bill should be submitted to the Europa dealer. All incidental charges in the course or repair / rectification shall be borne by the consumer / purchaser.

Liability of / for any consequential loss or damage is neither accepted nor implied and is expressly excluded.
Note : Kindly preserve this document carefully.

During renovation (Painting/construction work) Cover key hole / cylinder to avoid dust entry by adhesive tape. Do not use oil in lock assembly for cleaning. Use "ZORRIL 88" (a Pidilite Product) WD40 For Cleaning.

CENTRE SHUTTER LOCK - MODEL: S110

INSTALLATION PROCEDURE:

The EUROPA Center Shutter Lock is a high security locking system and it has to be installed correctly to ensure trouble free performance. Only an experienced technician should install it, strictly following the instructions mentioned below. Please contact your nearest Europa Lock dealer if you require any assistance.

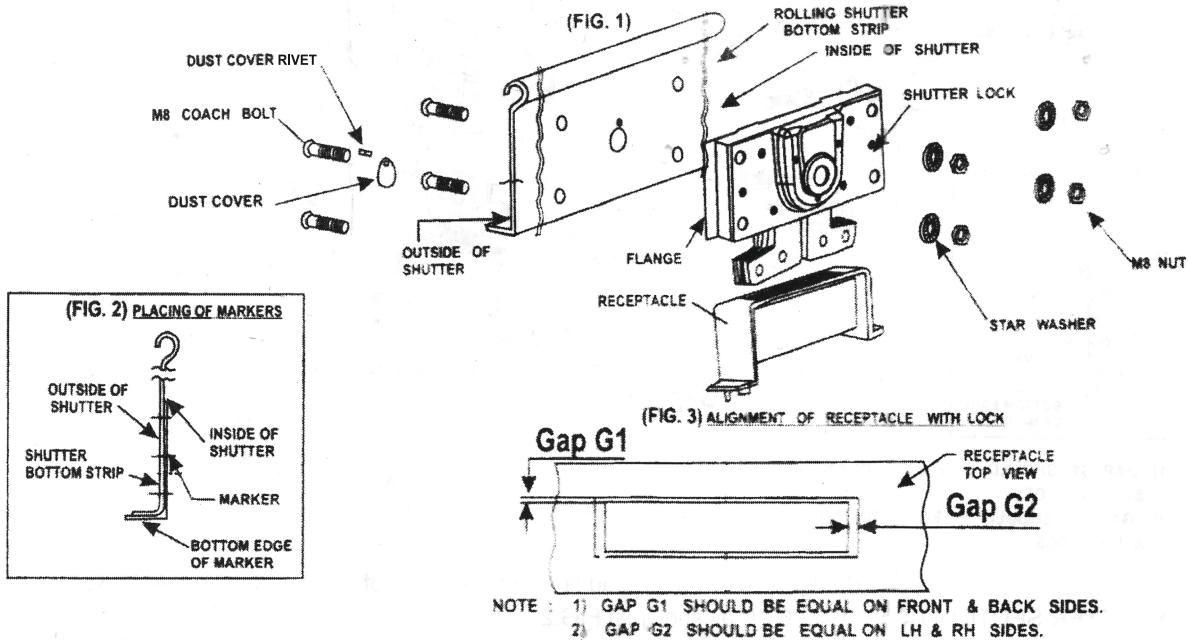

1. Fold the MARKER along the bottom edge (shown by dotted line). From inside of shutter place the MAEKER on the SHUTTER SECTION BOTTOM STRIP as shown in FIG.2
2. Mark centers 'A', 'B', 'C', 'D', 'P', and 'Q' (as shown on the MARKER) with center Punch. During marking ensure that the bottom edge MARKER should match to the bottom ben edge of SHUTTER bottom strip.
3. Drill 9mm.Dia. holes at centers 'A', 'B', 'C' and 'D' for mounting the lock.
4. Drill 18mm Dia. hole at center 'P' and 3mm Dia. at center 'Q'
5. To prevent the dust entering through the key hole, rivet the DUST COVER on the SHUTTER from outside at center 'Q' with RIVET supplied.
6. Fix the LOCK on the SHUTTER using M8 COACH BOLTS (provided with lock set). Two side FLANGES are provided for welding the LOCK with shutter. (IF POSSIBLE AVOID WELDING).

FIXING RECEPTACLE:

Use cement concrete mixture for fixing RECEPTACLE assembly. As shown in Fig.3 LOCK should enter the Receptacle in centered position so that there is equal gap on FRONT and BACK sides and on R.H. & L.H. sides. (Before pouring concrete mixture, keep engaged the two end locking levers of the Shutter.)

FINAL CHECKING OF LOCK OPERATION :

CONFIRM LOCK FUNCTION AS FOLLOWS

1. To LOCK the SHUTTER LOCK rotate the key by 360° anti clockwise direction. To OPEN it rotate the key by 360° clockwise direction. To remove the key, it should be on its original position in both cases.
2. To confirm opening & closing of the LOCK possible, in wet condition of concrete.



DKL KEY REGISTRATION CARD

Key No. :- _____

To obtain spare duplicate keys, kindly fill in and send this card to the company, spare keys can not be supplied to you without this card

Customer Name :- _____ Address to which keys are to be sent :- _____

Quantity of spare keys required _____ Nos. Date _____ Signature _____

48 HOUR SPARE KEY SERVICE

The company will arrange to manufacture duplicate spare keys within 48 working hours from the date of receipt of this card in this factory premises.

(This time period of 48 hours does not include the time taken for this card to reach the Co; the time taken for the keys to reach the consumer after they leave the company. It excludes weekly off festival & national holidays as well as delays due to power cut material/tool shortages labour unrest m/c breakdown and other delays normally experienced in a factory)

The keys will be sent through courier on advance payment basis, on receipt of above mentioned essentials. The appropriate charge for spare keys ruling at that time will be payable by the consumer.

Please Make (✓) For Right Key Type

<input type="checkbox"/>	<input type="checkbox"/>
<input type="checkbox"/> DCL (Small) KEY	<input type="checkbox"/> 5 PIN KEY
<input type="checkbox"/> DKL (Big) KEY	<input type="checkbox"/> LIGHT KEY
<input type="checkbox"/> SMART KEY	<input type="checkbox"/> SL KEY